

Models

H-4 H-5 SBH-5 HBH-5 TBH-5

Installation & Operating Instructions

WARNING:
**Do NOT attempt to install
or operate this equipment
until fully reading and
understanding these
instructions.**

1220 Industrial Drive Dewey, OK 74029

(918) 534-0000

www.deweyhoist.com

Table of Contents

Section 1	Precautions & Warnings	Page 3
Section 2	Specifications	Page 5
Section 3	Typical Hoist Installation	Page 6
Section 4	Installation Instructions	Page 7
Section 5	Parts	Page 11
Section 6	Support Prop Installation	Page 12
Section 7	Hoist Operation	Page 13
Section 8	Hoist Daily Inspection Report	Page 14
Section 9	Terms, Conditions & Warranty	Page 15

Section 1 Precautions & Warnings

PLEASE!

Read and follow these rules.

Not following these rules may void the warranty and
Could result in injury or death!

- **READ ALL INSTRUCTIONS:** Be sure to read the installation and operations instructions that came with your specific hoist or product. If you have questions please call Dewey Hoist for assistance.
- **DO NOT ALLOW ANYONE TO OPERATE A DUMP SYSTEM UNLESS THEY HAVE READ THESE CAUTIONS AND THE INSTRUCTIONS.**
- **DO NOT ALLOW OTHER PERSONS AROUND DUMPING:** Keep all persons at least 30 feet away when dumping.
- **DO NOT OVER LOAD:** The combined weights of the trailer chassis, hoist pump kit, platform/body (box), and payload must not exceed the Gross Vehicle Weight Rating (GVWR), the Gross Axle Weight Rating (GAWR) of the trailer. Additionally, hitch/pin weight and the combined weights of the tow vehicle and trailer must not exceed tow vehicle manufacturers tow ratings or Federal, State, or Local law. Trailer must be equipped with operational brakes. Trailer must be loaded evenly.
- **USE A REVERSE SIGNAL ALARM:** Be sure the vehicle is equipped with a reverse signal alarm audible above the surrounding noise level or backup only when an observer signals it is safe.
- **DO NOT LIFT BODY ON SOFT OR UNEVEN SURFACE:** Even slight angles or soft ground can result in a rollover of the.
- **DO NOT DRIVE WITH BODY RAISED:** Driving can result in a rollover or failure of hoist.
- **STAY 50 FEET OR MORE FROM POWER LINES:** Always check overhead for power lines before raising body.
- **ALWAYS SHIFT CONTROL VALVE TO NEUTRAL AND DISENGAGE PTO AFTER DUMP ANGLE IS ACHIEVED:** Always disengage PTO when hoist is not in use or when moving vehicle.

DANGER:

JERKING VEHICLE MAY CAUSE HOIST FAILURE.

Driving forward fast or jerking the box sharply when raised will overextend the hoist or cylinder and may result in hoist failure that could result in SERIOUS INJURY OR DEATH.

- **DO NOT INCREASE HYDRAULIC PRESSURE:** Hoist must be operated at the correct pressure as indicated on the metal identification tag. Hoist may require a relief valve set at the correct pressure. Operating hoist at higher than rated pressure **WILL VOID THE WARRANTY** and could result in hoist failure, injury, or death.
- **NEVER ALLOW ANYONE UNDER UPLIFTED BODY WITHOUT PROP AND CRIBBING:** Lifted or lifting bodies (boxes) may fall suddenly and cause injury or death. Body (box) may fall in 1 second if a failure occurs with hoist, hoses, hydraulics, etc.
- **ALWAYS USE BODY PROPS AND SECONDARY STOPS:** When servicing hoist or body (box) use 2 methods of stopping the body (box) from falling. Example: Cribbing between frame and sills AND a prop between body (box) and ground. **BODY PROP WILL NOT SUPPORT A LOADED BOX.**
- **DO NOT LEAVE RAISED OR PARTLY RAISED BODY UNATTENDED.**

DEWEY HOIST Installation and Operating Instructions

- **INSPECT VEHICLE:** Regularly inspect the vehicle to see that all safety equipment regulations required by Federal, State or Local authorities have been followed.
- **NEVER ATTEMPT MAINTENANCE OR REPAIRS WITHOUT READING AND FOLLOWING THE INSTRUCTIONS :** Do not adjust valves, fittings, cables, electric wires, etc. without the body prop and frame cribbing in place. Attempting to service these items may result in the body (box) unexpectedly falling. Always follow maintenance procedures found in instructions. **YOU CAN NOT OUT RUN A FALLING BOX!** Body (box) may fall completely down in 1 second.
- **MAINTAIN HOIST IN GOOD WORKING ORDER:** Maintenance should only be performed by qualified technicians. Visually inspect hoist, body, and truck each day for loose items, cracks, broken welds, worn hoses, etc. **All joints should be greased every 6 months. DO NOT ALLOW HYDRAULIC OIL TO BECOME LOW.** Low amounts of hydraulic oil will result in jerky or shaky motion and may lead to hoist failure.

Danger label must be affixed to frame of hoist and on the outside of the box where it can be read with the box in the down position.



KEEP WARNING DECALS IN GOOD CONDITION: We will provide FREE additional warning decals/labels or instructions for your hoist. Please contact Dewey Hoist at (918) 534-0000. Keep all guards in place.

WARNING!

If you believe that your vehicle has a defect caused by the hoist installation which could cause a crash or injury you should call Dewey Hoist before using or driving that vehicle. Dewey Hoist 918-534-0000.

PLEASE!

Read and follow these rules.
Not following these rules may void the warranty and
Could result in injury or death!

Section 2 Specifications

DEWEY HOIST Installation and Operating Instructions

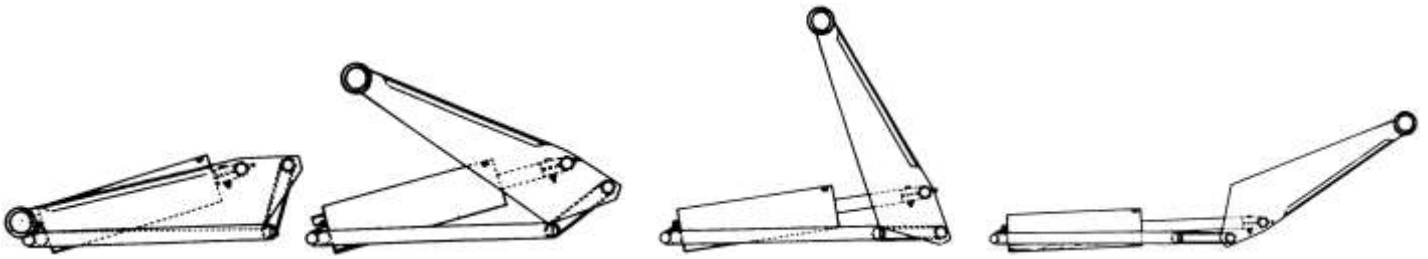

Unique 'Advantage Linkage' increases the lifting power at the beginning of lift.

The center line of the cylinder is at 90° to centerline of hinge point which gives maximum lifting power at the start of the lift where it is most needed.

Note ratio of lift to piston travel is increasing to maintain the most efficient leverage as hinge point is gradually changing.

Hinge point has changed smoothly as load continues to raise, permitting the lifting action to continue at maximum power & efficiency.

Hinge point has moved to give maximum height. Note the extremely high lift obtainable by using the Advantage Link.

Only Dewey Hoists have the 'Advantage Linkage'!

The 'Advantage Linkage' allows the Dewey Hoist to lift heavier loads with less hydraulic pressure. The linkage actually increases the lifting power of the hoist from 20 – 50% during that difficult first few inches of rise. This means that for a hoist rated at 22 tons it may develop over 27 tons in the beginning. The linkage also allows us to produce the highest lift and lifting angles possible without sacrificing power. This insures that your load will dump where you want and when you want. Our standard hoist may lift higher than the competitions "Hi-Lift" models. The 'Advantage Linkage' also allows the hoist to be placed as far back as possible in the truck frame without interference with the axle housing.

Designed Just for Trailers

Our trailer hoists are the only dump hoist designed specifically with the high lift necessary for trailer applications. There is nothing hanging under the trailer to hang up or be damaged. We can supply complete trailer hoist kits including Frame, Cylinder, Brackets, and 12V pump.

Specifications	Dewey Trailer Hoist Models				
	H-4	H-5	SBH-5	HBH-5	TBH-5
Ton Capacity (max.)	5	5	6	6	10
Box Length	8-10 ft.	8-10 ft.	8-12 ft.	10-12 ft.	10-14 ft.
Cylinders Required	1	1	1	1	2
Cylinder Bore X Stroke	4 X 13	5 X 14	5 X 14	5 X 14	5 X 14
Cylinder Action	Single	Single	Single	Single	Single
Height Collapsed	10 in.	10 in.	10 in.	11 in.	11 in.
Height Extended	55 in.	58 in.	66 in.	84 in.	84 in.
Operating Pressure	1750 psi.	1500 psi.	1500 psi.	1500 psi.	1500 psi.
Oil Capacity (pump)	4.5 qt.	4.5 qt.	5 qt.	5 qt.	5 qt.
Bracket Kit (optional)	BHK-70	BHK-70	BHK-71	BHK-72	BHK-73
Ship Weight Hoist	122#	134#	176#	218#	359#
Ship Weight Bracket Kits	27#	27#	40#	47#	56#

Chart Based on the following conditions:

1. Load being equally distributed in box
2. Operating pressure is correct.
3. Hoist is mounted as per the instructions.

Section 3 Typical Hoist Installations



Capacity is based on a 14 ft. box with an evenly distributed load and must include the weight of the box (body).

Please call Dewey Hoist (918) 534-0000 if you have any questions about mounting a hoist or about hoist lifting capacity.

Section 4 Installation Instructions

MODELS: H-4 H-5 SBH-5 HBH-5 TBH-5

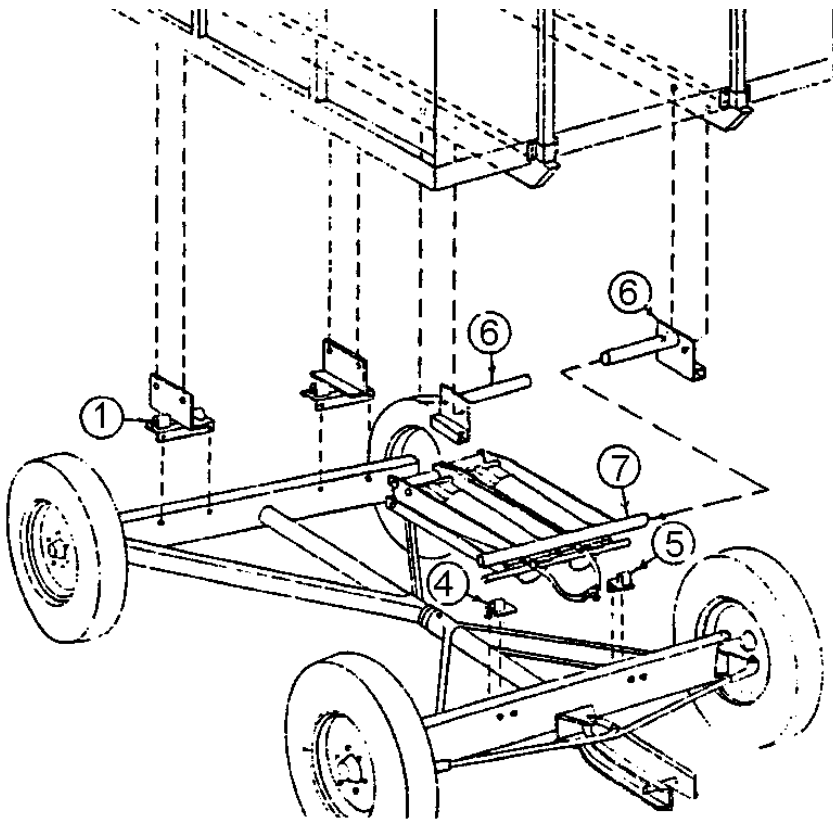

1. Remove trailer body (box) if so equipped.
2. Locate hinges (1) on rear cross member of trailer to match up with sills on body.
3. Bolt or weld hinges to FRONT of cross member and body sills. Remember to allow for the rub strips between body and frame.

WARNING:

If weld of the rear hinge is not completed securely with good welding practices, the body can fall under load causing equipment damage and possible serious injury or death.

4. Raise the front of the body several feet if possible.
5. Position lower hold-down bracket and hoist on trailer frame, locate hoist with the front hold down bracket 12-18" from front of trailer.

WARNING:

Hoist front hold down brackets **MUST** be located on a cross member. We recommend a cross member made of 4" X 4" X 1/4" Square tubing.

6. If back half of hoist does not rest on a cross member of the trailer frame, a cross member should be added to support the hoist.

IMPORTANT:

The lower arms of the hoist **MUST** be parallel to the ground when the hoist is in the down position and resting on the cross members. **DO NOT** position hoist closer to rear hinge or capacity will be proportionately less than rating. Lower hold-down bracket must be centered and square with trailer frame.

7. Bolt or weld front hold down brackets to cross member.
8. Bolt 1" X 3" hardwood boards or poly strips to the top of the trailer frame as a "rub strip"
9. Mount pump kit according to instructions packed with pump kit.
10. Lower body into position. Some bodies may require notching of cross members so that long sills sit flush on boards and clear hoist.
11. Before fastening the sill supports to the long sills of the body, make certain the hoist is in a closed position such that the side arms of the hoist rest against the hinge tube as shown below. Tack weld the sill supports to the long

DEWEY HOIST Installation and Operating Instructions

sills, raise the body and block safely. Bolt or weld sill supports to sills using 1/4" minimum continuous weld with E-6013 welding rod or equivalent. Do not skip or stitch weld.

NOTE: Side arms must contact hinge tube of linkage and must be parallel (level) with truck frame.

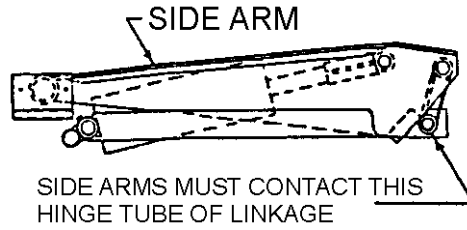

All Dewey Hoist systems are load rated based on an equally distributed load in the cargo box. Ratings assume that the product (dirt, rock, gravel, etc.) is diminishing by flowing out of the box as load is lifted.

DANGER:

Never exceed the operating pressure for a hoist model.

HOIST SYSTEM OPERATING PRESSURE					
	H-4	H-5	SBH-5	HBH-5	TBH-5
Operating Pressure	1700 psi	1500 psi	1500 psi	1500 psi	1500 psi

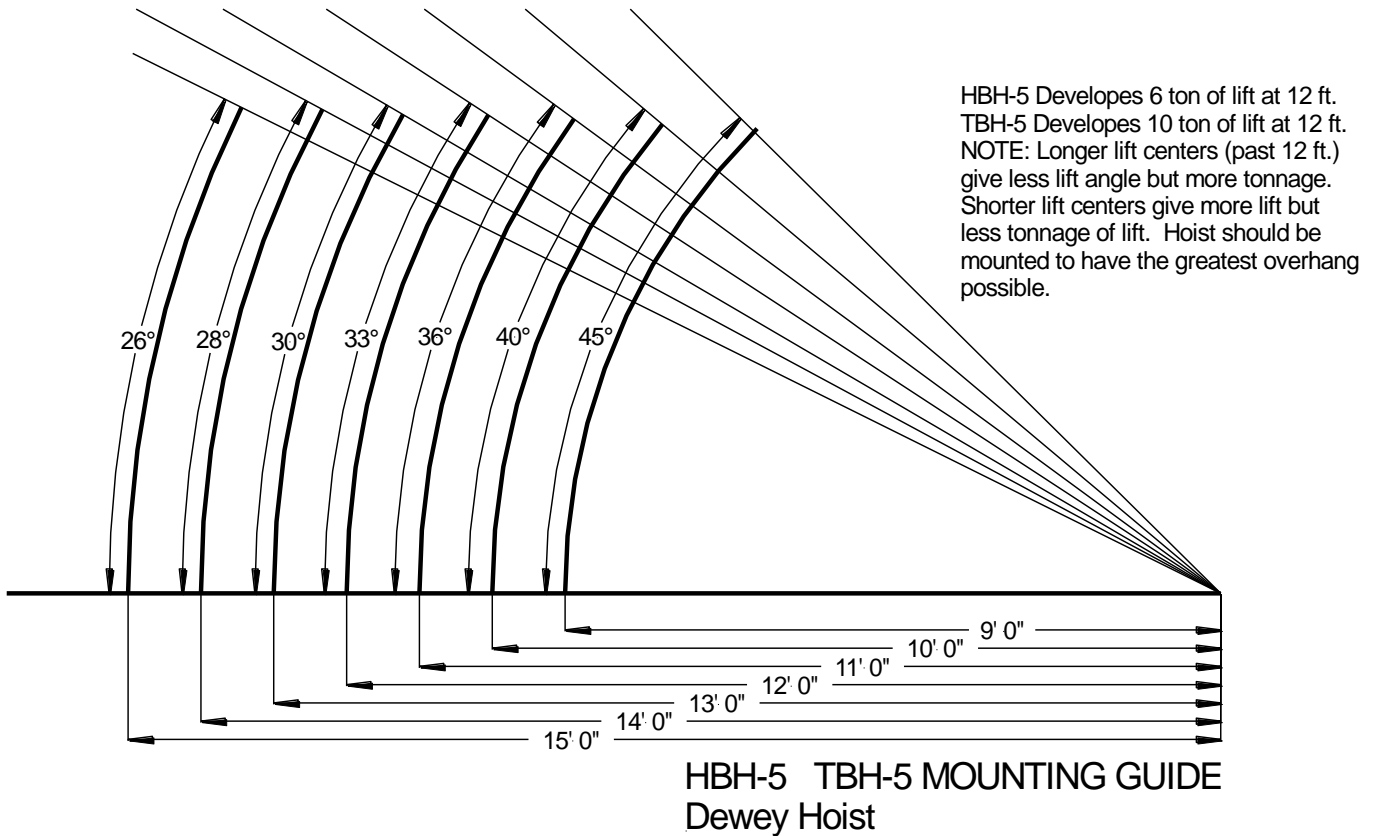

Additional Instructions for HBH-5 & TBH-5

DEWEY HOIST Installation and Operating Instructions

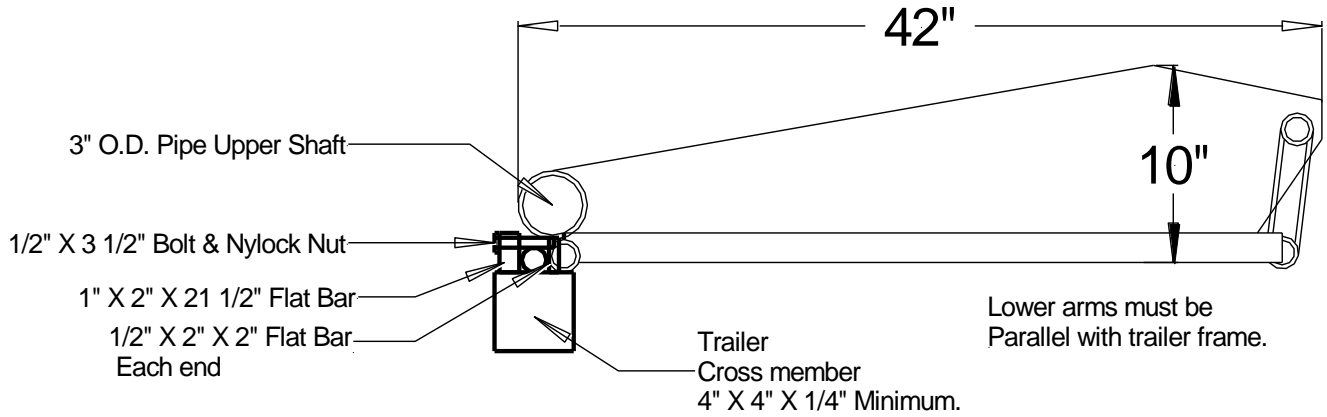

HBH-5 6 ton 82" Lift
 TBH-5 10 ton 82" Lift
 Designed for 12-14 ft. Trailer
 24" Rear overhang, 24" From Front of trailer

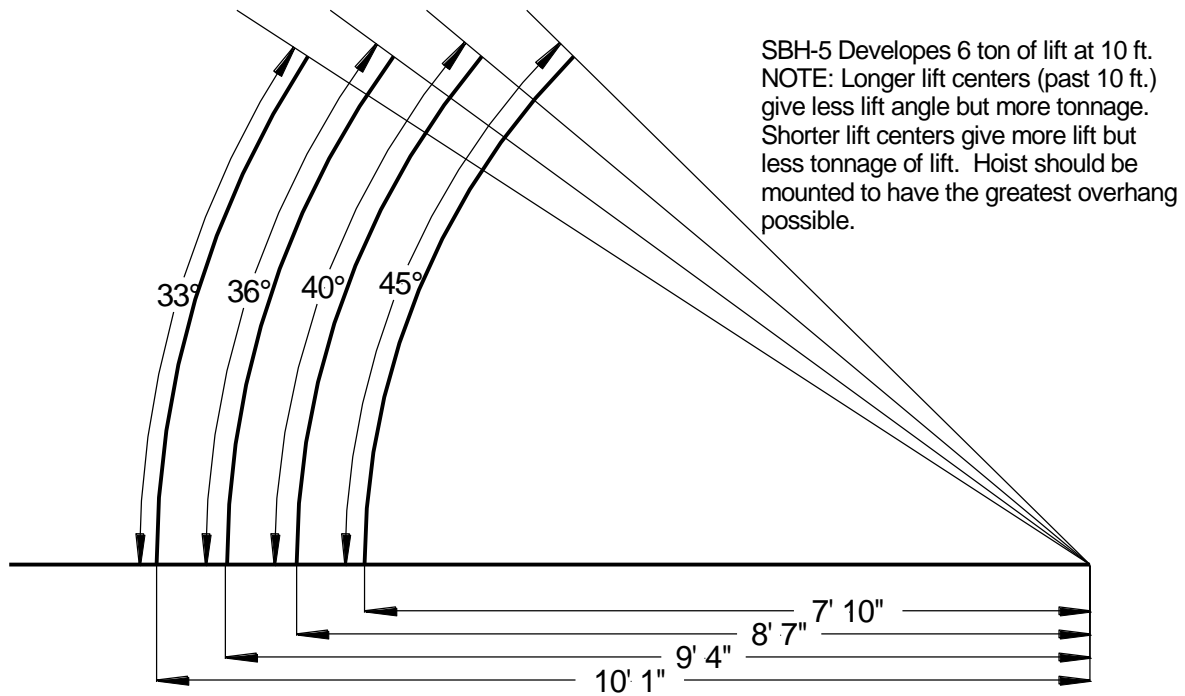

SBH-5 MOUNTING GUIDE Dewey Hoist

IMPORTANT:

DEWEY HOIST Installation and Operating Instructions

The lower arms of the hoist **MUST** be level or parallel with the trailer frame rails. Do not allow the rear of the hoist to hang down. You may need a rear bracket or support under the very back end of the hoist frame assembly.

It is very important that the 1" X 2" X 21 1/2" flat bar be stitch welded to the cross member both inside and out. All of the pressure of lifting is down and forward, the 1/2" X 2" X 2" flat bar and bolts are only for the retention of the hoist with the box in the down position.

Placing the 4" X 4" X 1/4" cross member under the trailer frame and leaving an opening in the box cross sills allows the minimum trailer height.

All hoist position measurements are from the center of the rear hinge shaft to the front pivot shaft of the hoist.

As with all hydraulic hoists, increasing the distance from the rear hinge to the lift point of the cylinder **INCREASES** lifting capacity and **DECREASES** the dump angle.

Box overhang behind the rear hinge acts as a counterbalance of load and **INCREASES** the load capacity of the trailer. Be careful in design that the overhang portion of the box does not contact the ground.

Section 5 Parts		HOIST MODEL				
DESCRIPTION	REF #	H-4	H-5	SBH-5	HBH-5	TBH-5
Hoist Frame	1	01168	01168	01190	01176	00807
Cylinder Assembly	2	07018	01170	07121	07076	07043
Sill Support	3	01312	01312	00549	02395	02395
Rear Hinge	4	1313/1314	1313/1314	0680/0682	0680/0682	00712
Front Hold Down	5	01311	01311	00682	00682	00682
Hinge Shaft (Cylinder)	6	09157	09157	09275	09223	06398
Set Screw (Cylinder)	Not Shown	80933	80933	80933	80933	80933
Seal Kit	Not Shown	09164	02682	06851	Call	09189

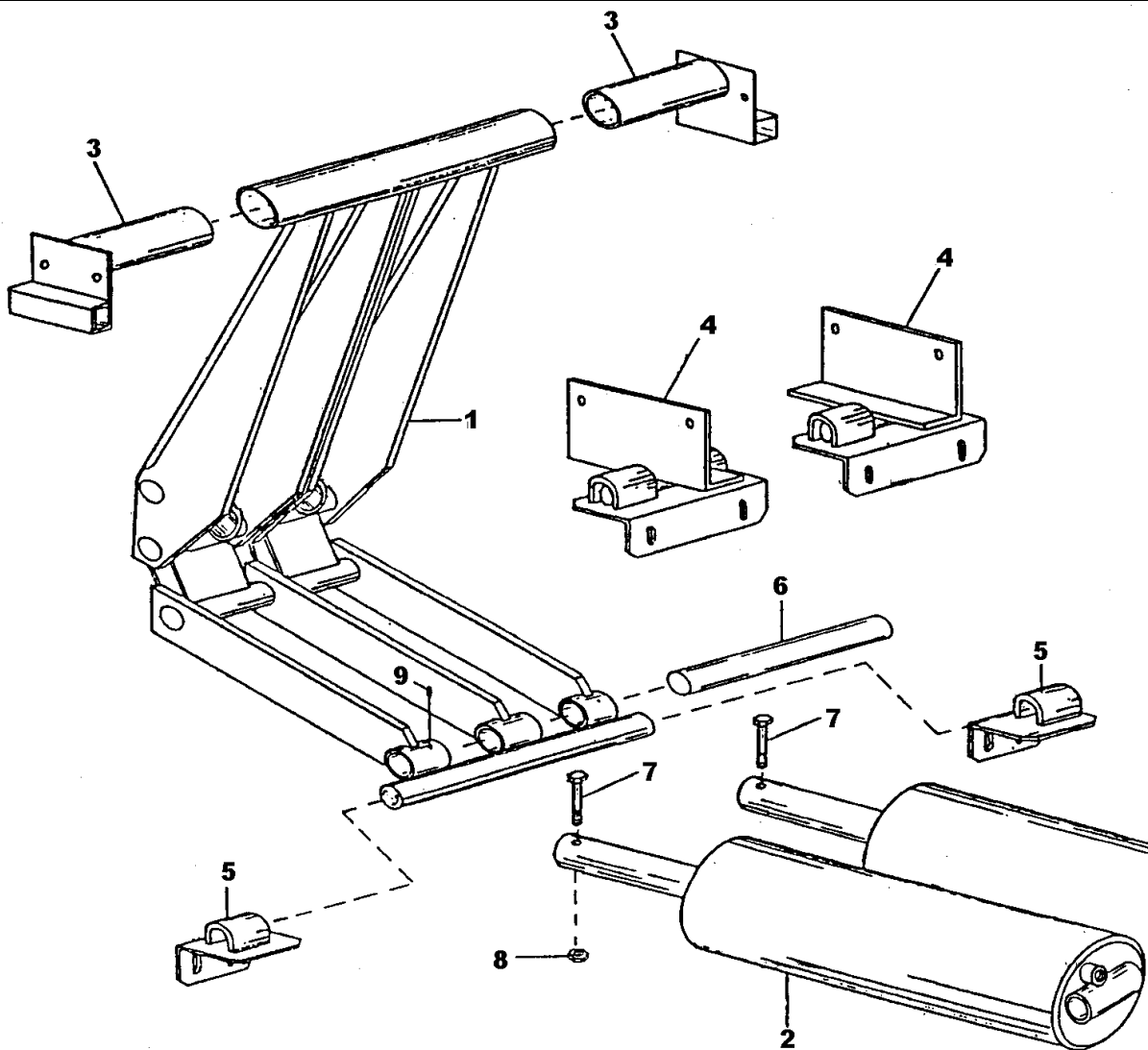

Section 6 Support Prop Installation

DANGER: NEVER GO UNDER A RAISED BODY WITHOUT ADDITIONAL SUPPORT OR CRIBBING!
Failure to follow instructions or attempting to hold up a loaded truck body without one or more props can result in serious injury or death.

1. As a general rule, one prop will support a dump body of 12 ft. or less in length. With longer bodies two props should be used, one on each side. If two body props are required, they must be mounted equal distance from the rear hinge, one on each side.
2. Raise body approximately $\frac{3}{4}$ of its maximum dump height and brace it securely or support it with overhead equipment before beginning installation. Do not raise body all the way.
3. Position and securely clamp pivot end of body prop to the body sill so that the body prop is vertical to and about 1" higher than the top of the truck frame. Grasp prop and make sure that it will fold up beside sill of box.
4. Allow prop to hang straight down and position the lower bracket on truck frame rail with prop all the way forward in the lower bracket. Drill and bolt lower bracket to truck frame rail.
5. Properly mounted the body prop will swing down to lower bracket and stand up at a 90° angle to truck frame.
6. Swing prop up to parallel with box long sill, locate and weld prop hanger bracket to sill.
7. When positioned correctly weld prop mount to box long sill with $\frac{1}{4}$ " minimum continuous weld with E-6013 welding rod or equivalent. Weld all 4 sides to sill.
8. Lubricate pivot end of body prop as necessary to insure free operation.
9. Place "Body Prop" Caution decal on body prop or on box close to prop.
10. To operate body prop raise body to desired height, shut off all power, grasp prop at arm length without going under raised box, pull out and allow to swing down. Push prop into lower bracket. Lower box slowly until prop contacts lower bracket. Crib with wood before working on or servicing anything under box.



CAUTION



DO NOT use body prop with a loaded body!
DO NOT power down hoist with body prop in place.

1. Raise empty box to proper height, BE SURE valve is going to hold up box.
2. Shut OFF all power. BE SURE box does not move.
3. Grasp prop at arms length, pull out, swing down. STAY OUT FROM UNDER BOX.
4. KEEP BACK, Lower box until prop supports box.
5. Prop MUST BE AT 90 degrees to truck frame. STRAIGHT UP & DOWN!
6. If Prop is not at 90 degrees, REPEAT steps 1 to 6.

Failure to KEEP AWAY may result in DEATH. CHOCK BOX BETWEEN FRAME & BOX!

Dewey Hoist918-534-0000

Section 7 Hoist Operation

IMPORTANT:

Read all cautionary statements. If you do not understand cautions and warnings DO NOT OPERATE DUMP SYSTEM.

1. Inspect truck, box, and hoist system. Visually inspect hoist, body, and truck and trailer each day for loose items, cracks, broken welds, worn hoses, etc. All joints should be greased every 6 mo.
2. Make sure truck and trailer are on a level surface, brakes are holding, and that load is stable and equally distributed in the box.
3. Stay in cab of truck while dumping.
4. Open windows on truck before attempting to raise body, turn off sound apparatus (radio, CB, etc.) so you can hear verbal instructions. Listen for unusual noise. STOP if system sounds abnormal.
5. Always check for overhead power lines, limbs, etc. before dumping.
6. Make sure that there are no persons behind truck or on either side within at least 30 feet.
7. Engage PTO, if so equipped. Do not race engine. Engine should run at idle speed.
8. Pull control knob on PTO to raise body. Press up switch on electric pump systems.
9. Check both mirrors continuously while dumping. STOP and let box down if you see anything unusual happening.
10. Do not "Jolt" load by jerking truck. This can result in hoist failure.
11. Do not drive truck with box in the up position.
12. After load has been dumped, move forward and lower body to the full down position. Lock tailgate before moving. Check that no product is still on tailboard of box.
13. Continually check that the rear tailgate is working properly and that no product is lost while driving.

Section 8 Hoist Daily Inspection Report

DEWEY HOIST DAILY INSPECTION REPORT

- Check at all warning / caution labels are in place and readable.
- Check hinges for cracks, broken welds, missing snap rings. Grease each day.
- Check box for loose parts, cracks, broken welds, signs of failure.
- Keep hoist system and pump unit clean.
- Check hoses and fittings for signs of wear, cracking, and leaks.
- Make sure that hoses and wiring are not touching any part of the driveline.
- Check all bracket bolts, pins, and welds for looseness or failure.
- Inspect hoist frame for cracks, loose pins, loose bolts, etc.
- Lubricate hoist grease fittings every 6 months or more often if in heavy use.
- Check hydraulic oil level & fill as needed. If oil is foamy or dirty, drain and replace.
- Check body prop system for cracks, broken welds, and loose fasteners.
- Check control cable on PTO systems for bends, fraying, broken casing.
- Check that PTO control cable and hoist valve cable move freely. DANGER read Caution Page.
- Check DC electric pump cables and wiring for frays, broken casing, rubbing.
- Check that all cords, cables, hoses, etc. are secured to chassis with clamps or wire ties.
- Check that all safety covers and guards are in place.
- Perform repairs to any problems identified in this inspection. If you are not qualified to repair hoist system please have repairs made by a dealer or call Dewey Hoist.

As with any piece of equipment your hoist system has a life span. Hard, continuous, or abusive use will shorten its life. Good maintenance and replacement of worn parts will extend its life. However do not attempt to repair a hoist after its useful life.

Do not attempt to repair a hoist that has suffered structural damage from wear, overloading, or a wreck. After structural members of a hoist or body have been subjected to great stress it may be impossible to visually ascertain all of the damage. To do so would entail x-ray or ultrasonic inspection. Remember if you repair the hoist system yourself you assume the risk and realize that you must comply with Federal, State, and Municipal regulations. You must also be aware that you might have changed the characteristics of your vehicle and could create a hazard for which you alone are responsible.

Section 9 Terms, Conditions & Warranty

**DIW ENGINEERING & FABRICATION, LLC
STANDARD TERMS AND CONDITIONS OF SALE
(INCLUDING DEWEY HOIST PRODUCTS AND ACCESSORIES)**

All sales and transactions with DIW Engineering & Fabrication, LLC (DIW) are subject to the following standard terms and conditions of sale:

1. LIMITED WARRANTY

- A. DIW warrants that the products manufactured by DIW, when properly installed and serviced and when properly used and maintained, shall be free from defects in material and workmanship for a period of one (1) year. DIW's obligation under this warranty shall be limited to replacing or repairing the part or parts or, at DIW's option, the products which prove defective in material or workmanship within one (1) year from the date of shipment from DIW, provided that BUYER gives DIW prompt written notice of any defect or failure and satisfactory proof thereof. Any defective part or parts must be returned to DIW's factory or to an authorized service center for inspection. BUYER will prepay all freight charges to return any products to DIW's factory or to any other repair facility designated by DIW. DIW will deliver replacements for defective products to BUYER, freight prepaid, to the destination provided for in the original order. Products returned to DIW for which DIW provides replacement under this warranty shall become the property of DIW.
- B. This limited warranty does not apply to product which DIW has determined to have been misused, abused, improperly maintained, mishandled or misapplied; or where the malfunction or defect can be attributed to the use of non-genuine DIW parts. Normal in-service wear of products or components is not covered by this warranty.
- C. In the event that any product is altered or repaired by BUYER or any person other than DIW's authorized service representative, without prior written approval by DIW, all warranties are void. Products and accessories supplied by but not manufactured by DIW are warranted only to the extent of and by the original manufacturer's warranty. A new warranty period shall not be established for any product repaired or replaced under warranty. Such items shall remain under warranty only for the remainder of the warranty period on the original materials, products or supplies.
- D. THE FOREGOING WARRANTIES ARE IN LIEU OF ALL OTHER WARRANTIES, WHETHER ORAL OR WRITTEN, EXPRESS OR IMPLIED, OR STATUTORY. IMPLIED WARRANTIES OF FITNESS FOR A PARTICULAR PURPOSE AND MERCHANTABILITY SHALL NOT APPLY. DIW'S WARRANTY OBLIGATIONS AND BUYERS REMEDIES THEREUNDER (EXCEPT AS TO TITLE) ARE SOLELY AND EXCLUSIVELY AS STATED HEREIN. FURTHER, IN NO EVENT WILL DIW (OR ITS SUBCONTRACTORS) BE LIABLE FOR ANY SPECIAL OR CONSEQUENTIAL DAMAGES. THERE ARE NO WARRANTIES WHICH EXTEND BEYOND THE DESCRIPTION ON THE FACE HEREOF.

2. LIMITATION OF LIABILITY

- A. The total liability of DIW (including its subcontractors) on any claim, whether in contract, tort (including negligence, whether sole or concurrent) or otherwise, arising out of, connected with, or resulting from the manufacture, sale, delivery, resale, repair, replacement or use of any products or the furnishing of any service shall not exceed the price allocable to the products or service hereof which gives rise to the claim.
- B. IN NO EVENT SHALL DIW (OR ITS SUBCONTRACTORS) BE LIABLE FOR ANY SPECIAL OR CONSEQUENTIAL DAMAGES, DAMAGES FOR LOSS OF REVENUE, COST OF CAPITAL, CLAIMS OF CUSTOMERS FOR SERVICE INTERRUPTIONS OR FAILURE OF SUPPLY AND COSTS AND EXPENSES INCURRED IN CONNECTION WITH LABOR, OVERHEAD, TRANSPORTATION, OR SUBSTITUTE FACILITIES OR SUPPLY SOURCES.

3. INDEMNIFICATION

- A. BUYER agrees to and shall indemnify, defend and hold harmless DIW, its officers, representatives and affiliated companies from and against any liability, damage, loss, expense, claim or judgment arising from injury or death of any person or damage to any property arising out of or in connection with or from the use of any application by BUYER or its customers, in conjunction with DIW or otherwise, or the results of DIW's services or any products assembled, installed or provided by DIW. It is the expressed intention of BUYER and DIW that the indemnity provided for in this Section is to protect DIW from consequences of negligence of BUYER and others, including that negligence which is a concurring cause of the injury, death or damage. Furthermore, the indemnity provided for in this Section shall have no application to any liability, damage, loss expense, claim or judgment where the injury, death or damage results from the sole negligence of DIW unmixed with the fault of any other person or entity.

4. DELIVERY

- A. DIW shall deliver the products to BUYER at DIW's factory dock or at such other site designated by DIW. Partial deliveries shall be permitted. Delivery dates are approximate and dependent on BUYER providing DIW with all monies, guarantees and information needed to permit DIW to immediately proceed with work and without interruption. DIW shall not be liable for any damage or loss whether arising directly or indirectly out of any delay in delivery.
- B. Delivery shall be taken by BUYER within fourteen (14) days of the dispatch to BUYER of a written request to take delivery of the products. If for any reason any portion of the products cannot be delivered when ready due to any cause, DIW may invoke its right under Section 6 hereof. In such event: (1) DIW's delivery obligations shall be deemed fulfilled and title and all risk of loss or damage shall thereupon pass to BUYER, (2) any amounts otherwise payable to DIW upon delivery shall be payable upon presentation of DIW's invoices and its certification as to such cause, and (3) all expenses incurred by DIW, such as for preparation for and placement into storage, handling, inspection, preservation and insurance, shall be immediately payable by BUYER upon submission of DIW's invoices therefore.

5. TITLE AND RISK OF LOSS

- A. Title to and risk of loss to the products will pass to BUYER at the time and place of delivery. BUYER will pay or reimburse DIW for all freight, preparation, and in-transit insurance costs from the time of delivery.
- B. The time, method, place or medium of payment will not in any way limit DIW's right in and to the products until payment has been received in full. On all orders, DIW shall retain a security interest in the products to the extent of any unpaid balance of the purchase price therefore, and DIW may use all reasonable efforts to retain and/or obtain possession of such products until such unpaid balance has been received and accepted by DIW.

DEWEY HOIST Installation and Operating Instructions

6. DELAYS

- A. The date on which DIW's obligations are to be fulfilled shall be extended for a period of time equal to the time lost by reason of any delay arising directly or indirectly from: (1) acts of God, unforeseeable circumstances, acts (including delay or failure to act) of any governmental authority (de jure or de facto), war (declared or undeclared), revolution, fires, strikes, labor disputes, sabotage or epidemics; (2) failure due to causes beyond DIW's reasonable control to timely obtain instructions of information from BUYER, necessary and proper labor, materials, components, facilities and transportation; or (3) any other cause beyond DIW's reasonable control. The foregoing extension shall apply even though such cause may occur after DIW's performance of its obligation has been delayed for other causes.
- B. If a delay resulting from any of the causes in Section 6A above extends for more than ninety (90) days and the parties have not agreed upon a revised basis for continuing the work at the end of the delay, including adjustment of the price, then either party, upon thirty (30) days written notice, may terminate the order in respect to the undelivered portion of the products, whereupon BUYER shall immediately pay DIW's cancellation charges set forth in Section 7B.

7. CANCELLATION

- A. BUYER may cancel an order at any time prior to the date of shipment by giving notice to DIW. Notice shall be given in the most expeditious means possible and shall be confirmed within five (5) days thereafter, in writing, by facsimile transmission or by email.
- B. BUYER shall pay, upon the cancellation of any order, all costs for products shipped and work performed prior to receiving the cancellation notice plus DIW's cancellation charges. Cancellation charges shall be 15% of the catalog price of standard catalog products and 100% of the cost of special ordered products, but in no event will any cancellation charge be less than Fifty US Dollars (\$50.00) per order.

8. PAYMENT

- A. Unless DIW otherwise agrees in writing to terms other than those specified herein, payment shall be made to DIW as follows:
- i. All payments shall be made in US Dollars
 - ii. Payment shall be made within thirty (30) days after the date of DIW's invoice to BUYER. A monthly interest charge at the rate of two percent (2.0%) per month or the maximum legal rate, whichever is less, will be assessed on all payments past due.

9. TAXES

- A. All prices are exclusive of any applicable federal, state or local purchase tax, sales use, excise or other similar taxes, levies, fees or duties. Any taxes, levies, fees or duties by any governmental authority in connection with this transaction, excluding income taxes to DIW, shall be for Buyer's account and shall be paid directly by BUYER to the governmental authority concerned. If DIW is required by law or otherwise to pay any such taxes, levies, or duties and/or any fines, penalties or assessments as a result of BUYER's failure to comply with any applicable laws or regulations governing the payment of such taxes, levies or duties by BUYER, the amount of any payments so made by DIW together with a service charge of seven percent (7%), and shall be immediately reimbursed by BUYER to DIW upon submission of DIW's invoices therefore.

10. CONFIDENTIAL INFORMATION

- A. BUYER acknowledges that the successful operation of DIW's products may require repair or service by DIW's authorized representatives who possess valuable and confidential information, data, and know-how relating to the manufacture, tolerances, capabilities and operation of DIW's products ("Confidential information"). DIW's Confidential Information was acquired by DIW after many years of effort and after significant expenditures of money. BUYER also acknowledges that any disclosure of DIW's Confidential Information to any third party may cause substantial damage to DIW. Therefore, BUYER agrees that any service or repair work performed by DIW or its authorized agent at BUYER's locations will be done only under circumstances where DIW's Confidential Information is, in DIW's sole determination, adequately protected.
- B. BUYER covenants and agrees that it will at all times hereafter keep all Confidential Information provided to BUYER in the strictest confidence and will not at any time hereafter directly, indirectly, or in any other manner disclose or assist in the disclosure of any of DIW's Confidential Information to any unauthorized person, firm, entity or corporation.

11. DEFAULT

- A. DIW has the immediate right to terminate any order from BUYER by giving written notice to BUYER in the event that BUYER defaults on or breaches any obligation hereunder, or if BUYER experiences any of the following events: dissolution, insolvency, filing of a voluntary petition in bankruptcy, adjudication as a bankrupt, appointment of a receiver, trustee or guardian for its business or an assignment for the benefit of creditors.
- B. If BUYER should on its part fail to observe or fully comply with any obligation contained herein, DIW shall be at liberty to sell or otherwise dispose of the products(s) in such manner as it deems fit. Any deficiency in price which may result in and all expenses attending a resale or attempted resale of such product(s) shall be paid by BUYER and recoverable from BUYER by DIW as damages. Any increase in price on resale shall belong to DIW.

12. RETURNS

- A. Standard catalog products which have not been damaged or used by BUYER may be returned for credit only if: (i) DIW gives written authorization for such return, (ii) the products are returned in accordance with DIW's reasonable shipping instructions, (iii) the products being returned are in original condition and (iv) the products are returned within six (6) months from the original shipment date. BUYER shall pay a restocking charge of 15% of the catalog price of the returned products. BUYER's credit for returned products shall be the invoice price less the restocking charge and any repair or cleanup charges. Any product returned without DIW's prior written authorization will not receive any credit. No credit will be allowed for special order products.

13. GENERAL

- A. The commodities, technology or software that DIW Engineering & Fabricating, LLC manufactures and/or makes available for export to the BUYER and/or reexport by the BUYER for another destination are subject to the licensing requirements of the Export Administration Regulations of the United States. Diversion contrary to U.S. law is prohibited. In addition, commodities, technology or software made available for export or reexport by DIW Engineering & Fabricating, LLC to the BUYER for countries currently under U.S. unilateral or bilateral embargo are subject to the licensing requirements of the U.S. Treasury, Office of Foreign Assets Control. Those countries are: Iran, North Korea, Cuba, Myanmar (Burma).
- B. Any sale by DIW to BUYER hereunder and the interpretation of these Terms & Conditions of Sale shall in all aspects be construed under and given legal effect in conformity with the laws of the State of Oklahoma, U.S.A.

DEWEY HOIST Installation and Operating Instructions

- C. This document may be translated into and signed in languages other than English; however, the English language version of this document shall control all interpretations hereof.
- D. All quotations of DIW are subject to change at any time prior to acceptance of an order and expire thirty (30) days from the date thereof.
- E. BUYER's acceptance of these Terms & Conditions of Sale has been induced by no representations, statements, warranties, or agreements other than those herein expressed. This document embodies the entire understanding of the parties and merges any previous agreements or understandings, written or oral, in effect between such parties relating to the subject matter thereof. No waiver or modification of any provision hereof shall be binding on DIW unless same is in writing and signed by duly authorized representatives of DIW.
- ANY PROVISIONS IN ANY OF BUYER'S OR DIW'S PREVIOUS CURRENT OR SUBSEQUENT PURCHASE ORDERS, QUOTATIONS, ACKNOWLEDGEMENTS OR OTHER CONTRACTS, AGREEMENTS OR WRITTEN FORMS APPLICABLE TO THIS SALE, WHICH ARE INCONSISTENT OR IN CONFLICT WITH ANY PROVISION HEREIN WILL BE VOID AND NOT ENFORCEABLE UNLESS SPECIFICALLY AGREED TO IN WRITING BY DIW.

DIW Engineering & Fabrication, LLC
P. O. Box 158
Dewey, Oklahoma 74029 U.S.A.
Phone (918) 534-0000 or (918) 534-0001 Fax (918) 534-0700
Rev 01/12/2011

Dewey Hoist is Proudly Made in the United States of America by



DIW Engineering & Fabrication, LLC

1220 Industrial Parkway
PO Box 158
Dewey, OK 74029

Sales (918) 534-0000
FAX (918) 534-0700

www.diwfab.com